

Carbohydrate Research Vol. 368, 2013

Contents

REVIEW

Research progresses on the key enzymes involved in sucrose metabolism in maize

pp 29–34

Xiaodong Ren, Junjie Zhang*

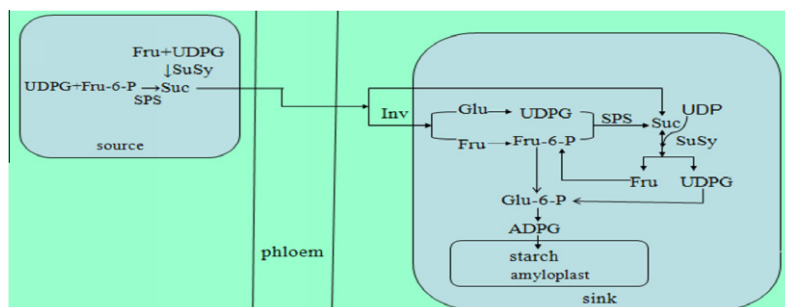

FULL PAPERS

Synthesis

Concise syntheses of potent chaperone drug candidates, *N*-octyl-4-*epi*- β -valinenamine (NOEV) and its 6-deoxy derivative, from (+)-*proto*-quercitol

pp 8–15

Shinichi Kuno*, Atsushi Takahashi, Seiichiro Ogawa

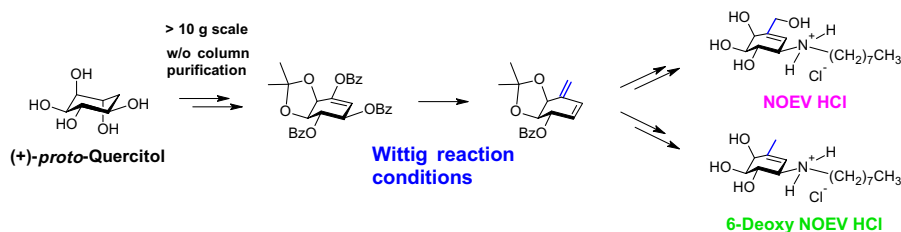

Concise synthesis of α -galactosyl ceramide from *D*-galactosyl iodide and *D*-lyxose

pp 35–39

Yu-Fen Yen, Suvarn S. Kulkarni, Chun-Wei Chang, Shun-Yuan Luo*

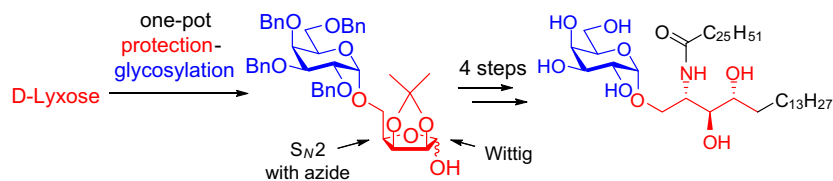

A concise pathway to synthesize a novel class of pyrido(2,3-d)pyrimidine-C- β -D-glycosides

pp 40–46

Muniyappapillai Jeganathan Shanmugam, Thangamuthu Mohan Das*

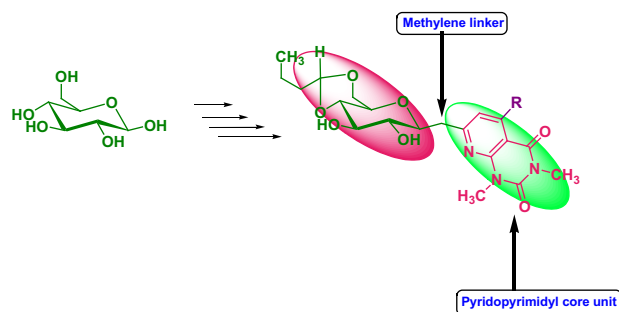

A straightforward access to TMG-chitooligomycins and their evaluation as β -N-acetylhexosaminidase inhibitors

pp 52–56

Sami Halila*, Eric Samain, Constantin E. Vorgias, Sylvie Armand

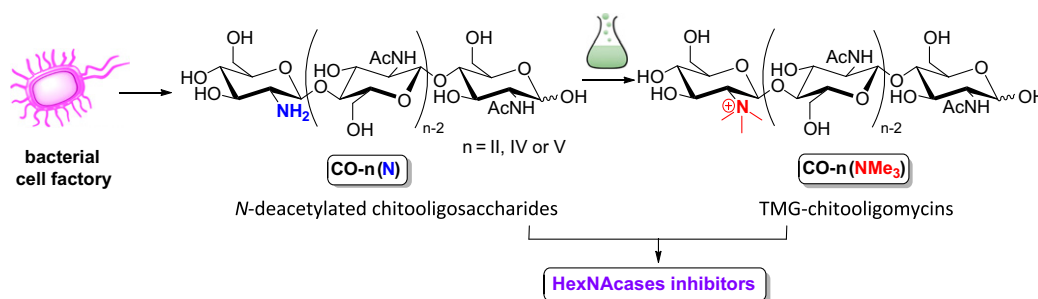

D-Glucose and D-mannose-based metabolic probes. Part 3: Synthesis of specifically deuterated D-glucose, D-mannose, and 2-deoxy-D-glucose

pp 111–119

Izabela Fokt, Stanislaw Skora, Charles Conrad, Timothy Madden, Mark Emmett, Waldemar Priebe*

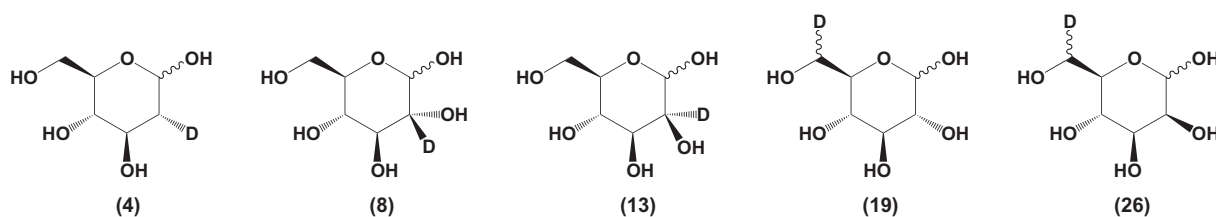

Biochemistry and Enzymes

Monitoring pathways of β -glucan degradation by enzyme mixtures in situ

pp 47–51

Bent O. Petersen, Ole Olsen, Sophie R. Beeren, Ole Hindsgaul, Sebastian Meier*

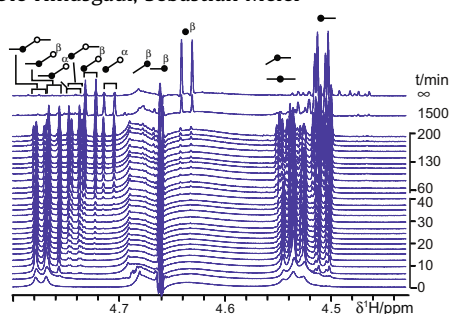

Comparing the acceptor promiscuity of a *Rosa hybrida* glucosyltransferase RhGT1 and an engineered microbial glucosyltransferase OleD^{PSA} toward a small flavonoid library

pp 73–77

Lu Wang, Weiqing Han, Chenying Xie, Jingli Hou, Qinghong Fang, Jianchun Gu, Peng George Wang*, Jiansong Cheng*

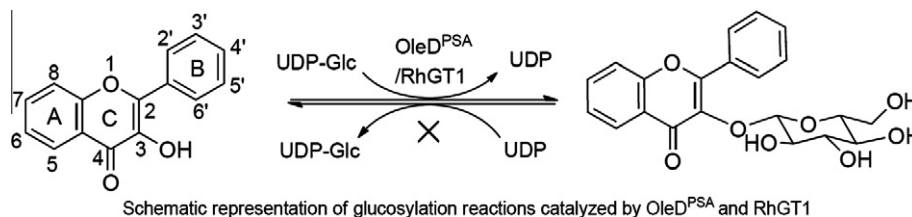

Enzymatic synthesis of 2-aminoethyl β-D-galactopyranoside catalyzed by *Aspergillus oryzae* β-galactosidase

pp 104–110

Cecilia Porciúncula González, Agustín Castilla, Lucía Garófaló, Silvia Soule, Gabriela Irazoqui, Cecilia Giacomini*

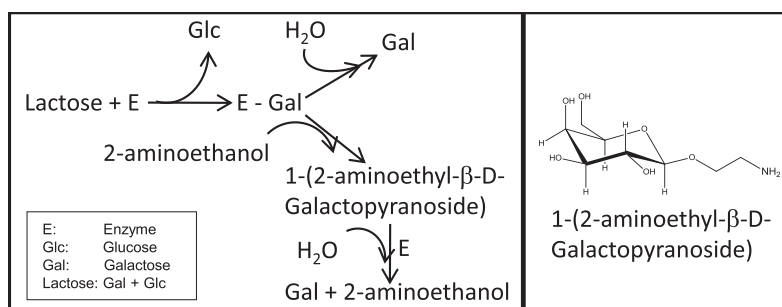

Characterization, Natural products

Triterpenoid saponins from rhizomes of *Paris polyphylla* var. *yunnanensis*

pp 1–7

Xia Wu, Lei Wang, Guo-Cai Wang, Hui Wang, Yi Dai, Xin-Xin Yang, Wen-Cai Ye*, Yao-Lan Li*

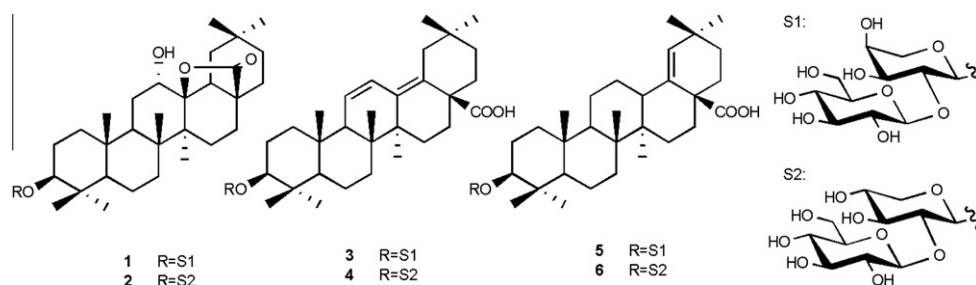

Structural characterization of the core oligosaccharide isolated from the lipopolysaccharide of the haloalkaliphilic bacterium *Salinivibrio sharmensis* strain BAG^T

pp 61–67

Sara Carillo, Giuseppina Pieretti, Buko Lindner, Ida Romano, Barbara Nicolaus, Rosa Lanzetta, Michelangelo Parrilli, Maria Michela Corsaro*

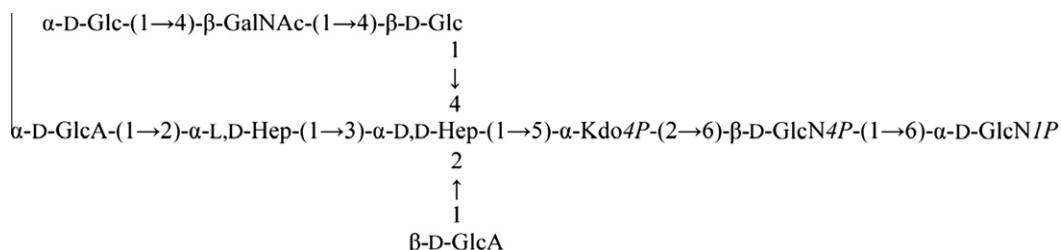

Polysaccharides**A heteroglycan from the mycelia of *Pleurotus ostreatus*: structure determination and study of antioxidant properties**

pp 16–21

Sukesh Patra, Pradip Patra, Kankan K. Maity, Soumitra Mandal, Sanjay K. Bhunia, Biswajit Dey, K. Sanjana P. Devi, Somanjana Khatua, Krishnendu Acharya, Tapas K. Maiti, Syed S. Islam*

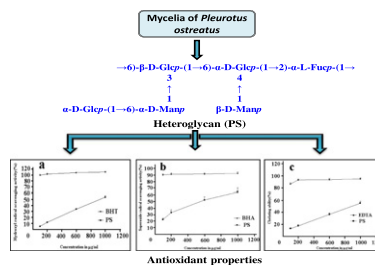
**Catalytic dehydration of fructose to 5-hydroxymethylfurfural over Nb_2O_5 catalyst in organic solvent**

pp 78–83

Fenfeng Wang, Hai-Zhen Wu, Chun-Ling Liu, Rong-Zhen Yang, Wen-Sheng Dong*

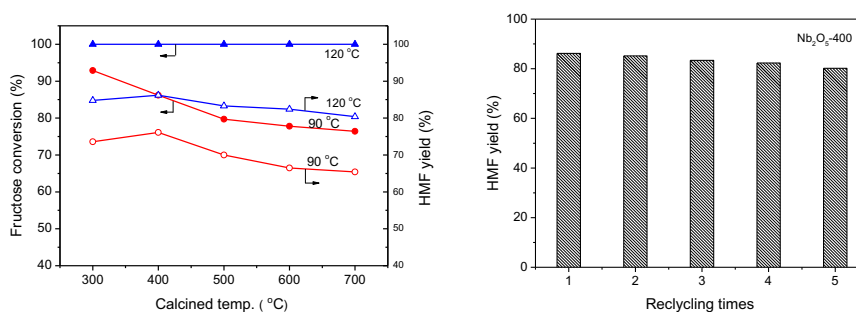
**Physical, X-Ray, Chromatography****Relaxometric determination of binding between Mn(II)–UDP and Mn(II)–UDP-glucose in aqueous solution**

pp 68–72

Etelka Farkas*, Orsolya Szabó, Gyula Tircsó, László Somsák*

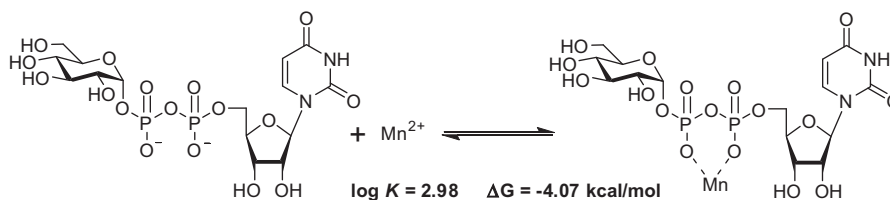
**Insights into the isomerization of xylose to xylulose and lyxose by a Lewis acid catalyst**

pp 89–95

Vinit Choudhary, Stavros Caratzoulas*, Dionisios G. Vlachos

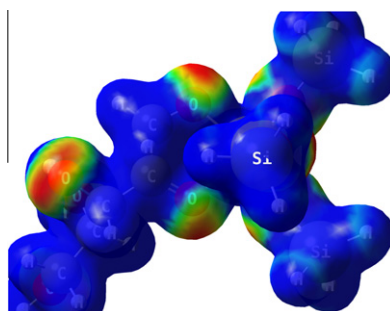

*Corresponding author

 Supplementary data available via SciVerse ScienceDirect

COVER

Multi-functionalisation of cyclodextrins (CD) has entered a new era thanks to the regioselective chemistry developed by M. Sollogoub's group. As illustrated on the cover, many applications can now be reached using CDs with various functions on specific positions. An example of functionalisation of CDs is given in the first issue of this journal. Image realised by Mickaël Ménand.

Available online at www.sciencedirect.com

SciVerse ScienceDirect

Abstracted/Indexed in: Chem. Abstr.: Curr. Contents: Phys., Chem. & Earth Sci. Life Sci. Current Awareness in Bio. Sci. (CABS). Science Citation Index. Full texts are incorporated in CJELSEVIER, a file in the Chemical Journals Online database which is available on STN[®] International. Also covered in the abstract and citation database SciVerse Scopus[®]. Full text available on SciVerse ScienceDirect[®]



ELSEVIER

ISSN 0008-6215